

DATA SHEET

For a complete data sheet, please also download:

- The IC06 74HC/HCT/HCU/HCMOS Logic Family Specifications
- The IC06 74HC/HCT/HCU/HCMOS Logic Package Information
- The IC06 74HC/HCT/HCU/HCMOS Logic Package Outlines

EEPW 电子产品世界
.com.cn

74HC/HCT365

Hex buffer/line driver; 3-state

Product specification
File under Integrated Circuits, IC06

December 1990

Hex buffer/line driver; 3-state

74HC/HCT365

FEATURES

- Non-inverting outputs
- Output capability: bus driver
- I_{CC} category: MSI

GENERAL DESCRIPTION

The 74HC/HCT365 are high-speed Si-gate CMOS devices and are pin compatible with low power Schottky TTL (LSTTL). They are specified in compliance with JEDEC standard no. 7A.

The 74HC/HCT365 are hex non-inverting buffer/line drivers with 3-state outputs. The 3-state outputs (nY) are controlled by the output enable inputs ($\overline{OE}_1, \overline{OE}_2$).

A HIGH on \overline{OE}_n causes the outputs to assume a high impedance OFF-state.

The "365" is identical to the "366" but has non-inverting outputs.

QUICK REFERENCE DATA

GND = 0 V; T_{amb} = 25 °C; t_r = t_f = 6 ns

SYMBOL	PARAMETER	CONDITIONS	TYPICAL		UNIT
			HC	HCT	
t _{PHL} / t _{PLH}	propagation delay nA to nY	C _L = 15 pF; V _{CC} = 5 V	9	11	ns
C _I	input capacitance		3,5	3,5	pF
C _{PD}	power dissipation capacitance per buffer	notes 1 and 2	40	40	pF

Notes

1. C_{PD} is used to determine the dynamic power dissipation (P_D in μW):

$$P_D = C_{PD} \times V_{CC}^2 \times f_i + \sum (C_L \times V_{CC}^2 \times f_o) \text{ where:}$$

f_i = input frequency in MHz

f_o = output frequency in MHz

∑ (C_L × V_{CC}² × f_o) = sum of outputs

C_L = output load capacitance in pF

V_{CC} = supply voltage in V

2. For HC the condition is V_I = GND to V_{CC}
For HCT the condition is V_I = GND to V_{CC} - 1.5 V

ORDERING INFORMATION

See "74HC/HCT/HCU/HCMOS Logic Package Information".

Hex buffer/line driver; 3-state

74HC/HCT365

PIN DESCRIPTION

PIN NO.	SYMBOL	NAME AND FUNCTION
1, 15	$\overline{OE}_1, \overline{OE}_2$	output enable inputs (active LOW)
2, 4, 6, 10, 12, 14	1A to 6A	data inputs
3, 5, 7, 9, 11, 13	1Y to 6Y	data outputs
8	GND	ground (0 V)
16	V _{CC}	positive supply voltage

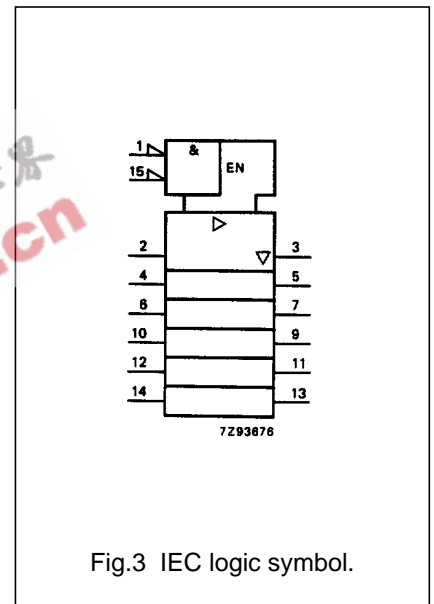
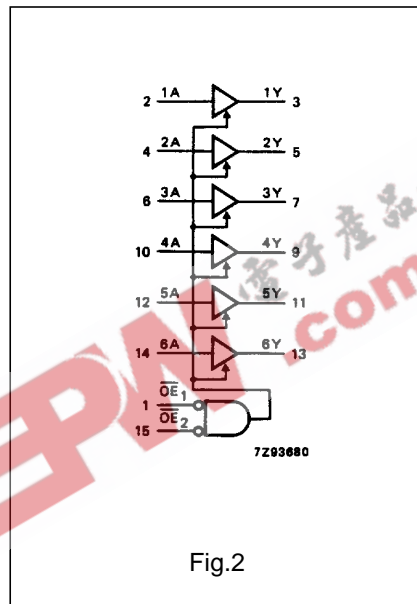
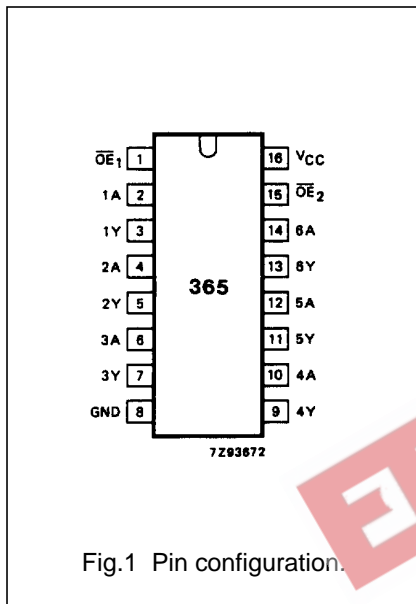

Hex buffer/line driver; 3-state

74HC/HCT365

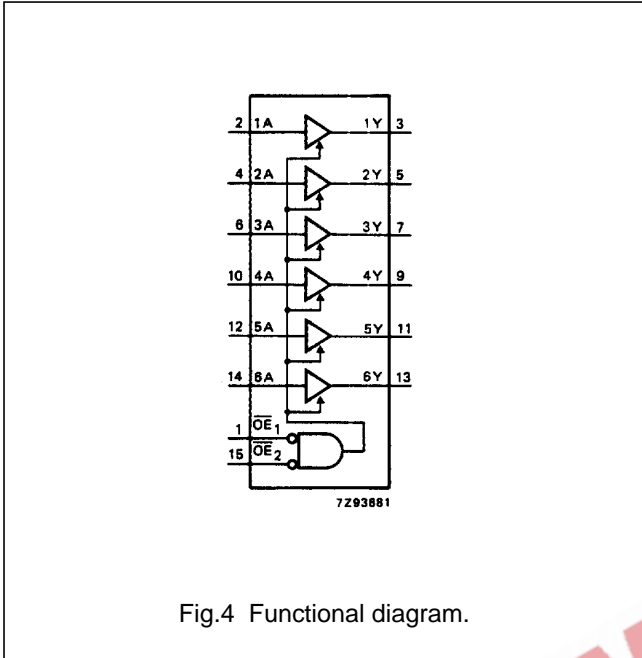

Fig.4 Functional diagram.

FUNCTION TABLE

INPUTS			OUTPUT
\overline{OE}_1	\overline{OE}_2	nA	nY
L	L	L	L
L	L	H	H
X	H	X	Z
H	X	X	Z

Notes

1. H = HIGH voltage level
 L = LOW voltage level
 X = don't care
 Z = high impedance OFF-state

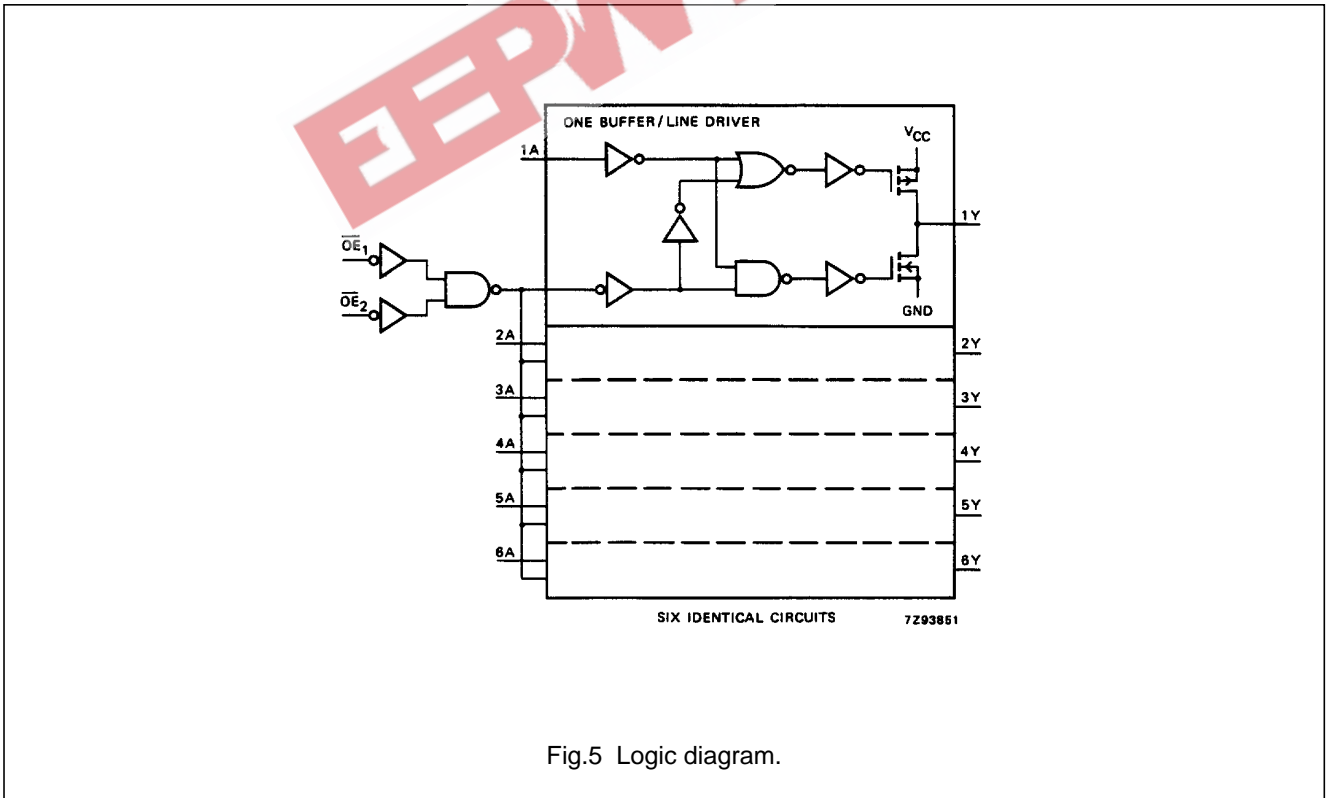

Fig.5 Logic diagram.

Hex buffer/line driver; 3-state

74HC/HCT365

DC CHARACTERISTICS FOR 74HC

For the DC characteristics see *"74HC/HCT/HCU/HCMOS Logic Family Specifications"*.

Output capability: bus driver

I_{CC} category: MSI

AC CHARACTERISTICS FOR 74HC

GND = 0 V; t_r = t_f = 6 ns; C_L = 50 pF

SYMBOL	PARAMETER	T _{amb} (°C)						UNIT	TEST CONDITIONS		
		74HC							V _{CC} (V)	WAVEFORMS	
		+25			-40 to+85		-40 to+125				
		min.	typ.	max.	min.	max.	min.				max.
t _{PHL} / t _{PLH}	propagation delay nA to nY		30 11 9	95 19 16		120 24 20	145 29 25	ns	2.0 4.5 6.0	Fig.6	
t _{PZH} / t _{PZL}	3-state output enable time \overline{OE}_n to nY		47 17 14	150 30 26		190 38 33	225 45 38	ns	2.0 4.5 6.0	Fig.7	
t _{PHZ} / t _{PLZ}	3-state output disable time \overline{OE}_n to nY		61 22 18	150 30 26		190 38 33	225 45 38	ns	2.0 4.5 6.0	Fig.7	
t _{THL} / t _{TLH}	output transition time		14 5 4	60 12 10		75 15 13	90 18 15	ns	2.0 4.5 6.0	Fig.6	

Hex buffer/line driver; 3-state

74HC/HCT365

DC CHARACTERISTICS FOR 74HCT

For the DC characteristics see *"74HC/HCT/HCU/HCMOS Logic Family Specifications"*.

Output capability: bus driver

I_{CC} category: MSI

Note to HCT types

The value of additional quiescent supply current (ΔI_{CC}) for a unit load of 1 is given in the family specifications. To determine ΔI_{CC} per input, multiply this value by the unit load coefficient shown in the table below.

INPUT	UNIT LOAD COEFFICIENT
\overline{OE}_1	1.00
\overline{OE}_2	0.90
nA	1.00

AC CHARACTERISTICS FOR 74HCT

GND = 0 V; $t_r = t_f = 6$ ns; $C_L = 50$ pF

SYMBOL	PARAMETER	T _{amb} (°C)						UNIT	TEST CONDITIONS		
		74HCT							V _{CC} (V)	WAVEFORMS	
		+25			-40 to+85		-40 to+125				
		min.	typ.	max.	min.	max.	min.				max.
t _{PHL} / t _{PLH}	propagation delay nA to nY		14	25		31		38	ns	4.5	Fig.6
t _{PZH} / t _{PZL}	3-state output enable time \overline{OE}_n to nY		18	35		44		53	ns	4.5	Fig.7
t _{PHZ} / t _{PLZ}	3-state output disable time \overline{OE}_n to nY		23	35		44		53	ns	4.5	Fig.7
t _{THL} / t _{TLH}	output transition time		5	12		15		18	ns	4.5	Fig.6

Hex buffer/line driver; 3-state

74HC/HCT365

AC WAVEFORMS

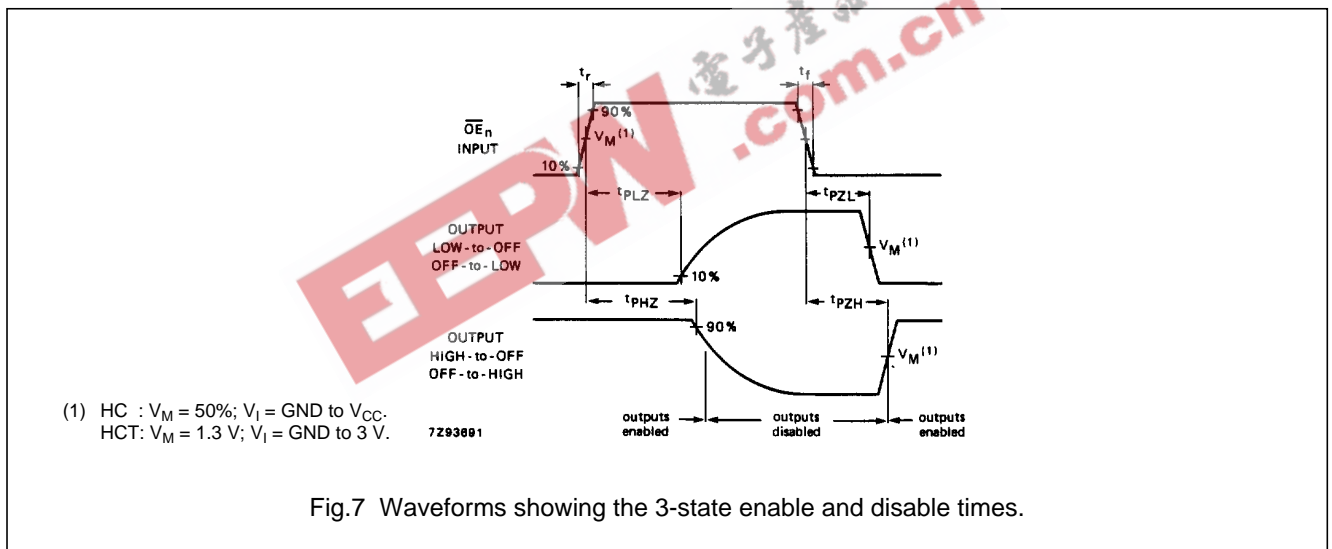
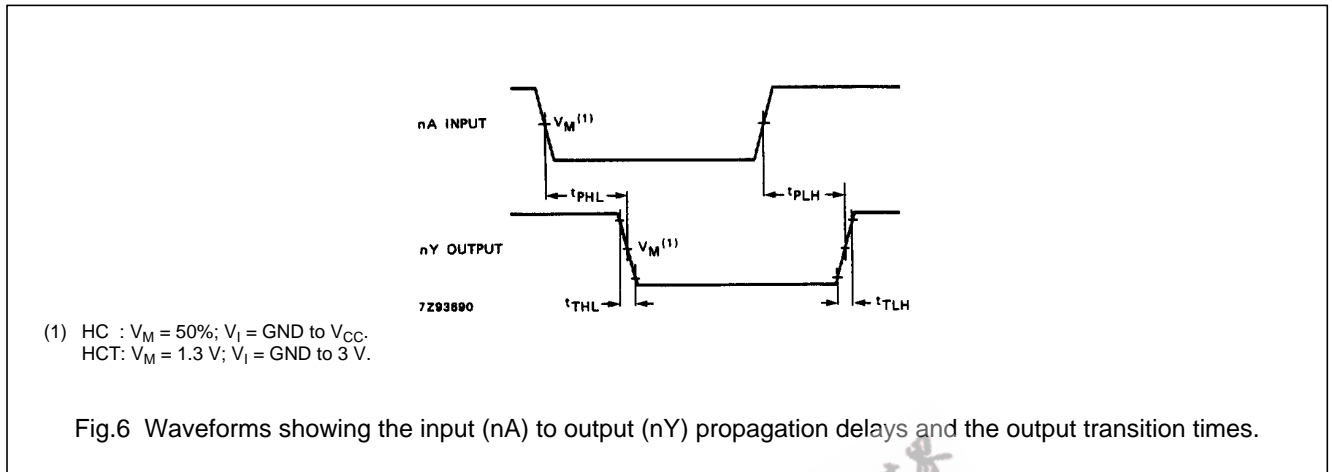

PACKAGE OUTLINES

See "74HC/HCT/HCU/HCMOS Logic Package Outlines".