

2.5 Gb/s CWDM Buried Het Laser 80Km reach LC25WC

This laser module provides a fast route to CWDM by providing a drop in replacement on existing TDM or WDM circuit packs with minimum redesign and verification work. The product employs the Bookham strained layer MQW Buried Heterostructure DFB laser chip, and has been designed specifically for use in Coarse Wavelength Division Multiplexed (CWDM) 2.5 Gb/s optical fibre trunk systems. The device is packaged in a hermetic 14-pin butterfly package incorporating an isolator and monitor photodiode for control of the power of the laser over life and all operating conditions.

The device is available with a number of power options depending on application and link span requirements.

Features:

- Drop in replacement onto TDM and WDM card
- 2.5 Gb/s operation
- Up to 10mW optical output power available
- Narrow spectral line-width
- Internal TEC with precision NTC thermistor for temperature control
- 1470nm to 1610nm at 20nm compliant to ITU G.694.2
- Code reduction with single product for reaches up to 80km
- GaInAsP SLMQW DFB single frequency laser chip
- InGaAs monitor photodiode
- Hermetically sealed 14-pin butterfly package with optical isolator
- RoHS compliant 

Applications:

- CWDM metro

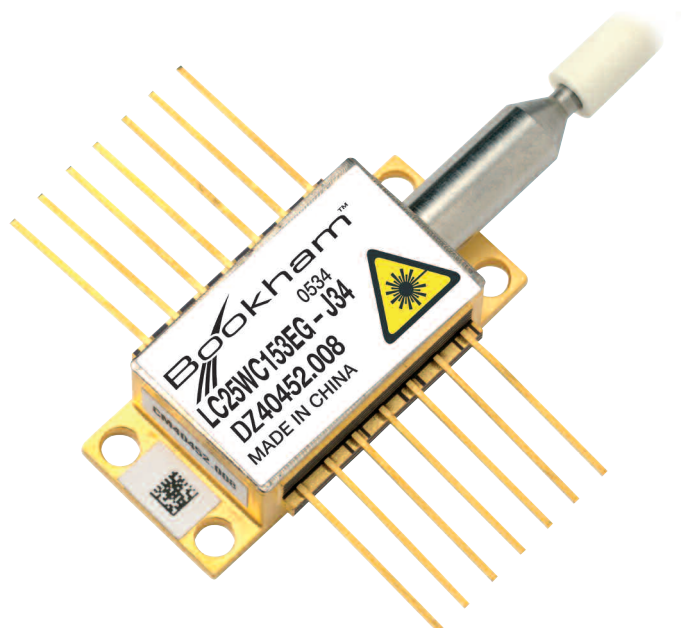

Parameters

Parameter	Conditions	Min	Typ	Max	Unit
Threshold current (I_{th})			10	22	mA
Slope efficiency by product	2 mW 3 mW 4 mW 10 mW	0.04 0.06 0.08 0.143		0.09 0.13 0.17 0.43	mW/mA
RF input reflection coef (S_{11})	[1]			-10	dB
Forward voltage			1.3	1.8	V
Channel wavelengths available	ITU G.694.2	1470		1610	nm
Peak wavelength for channel	[2]	$\lambda_p - 4\text{nm}$	λ_p	$\lambda_p + 4\text{nm}$	nm
Dispersion penalty at 80 km	[3]			2	dB
Time averaged spectral linewidth	-20 dB		0.1	0.6	nm
Side-mode suppression		30	40		dB
Optical rise/fall time	[4]			125	ps
Monitor photo current		50	250	1200	μA
Monitor dark current				100	nA
Thermistor resistance			10		k Ω
Heatpump current	70°C case temperature	250	600	900	mA
Heatpump voltage	70°C case temperature		1.0	2.4	V
Change of λ_p with laser temp.	20 to 35		0.09		nm/°C

[1] 50 Ω measurement system, $f = \text{dc} - 3 \text{ GHz}$.

[2] Submount temperature between 20°C & 35°C start of life to achieve required λ_p .

[3] Standard product dispersion penalty will be compliant to the specified link length of 80 km using an extinction ratio of 10 dB. Fibre dispersion characteristics are derived from the following equation

$$D(\lambda) = \frac{S_0}{4} \left(\lambda - \frac{\lambda_0^4}{\lambda^3} \right) \text{ps}/(\text{nm.km})$$

Where $S_0 = 0.092 \text{ ps}/(\text{nm}^2.\text{km})$ and $\lambda = 1302 \text{ nm}$.

[4] Measurements determined from 20 - 80% pk - pk.

Absolute Maximum Ratings

Parameter	Min	Max	Unit
Case operating temperature	0	70	°C
Laser submount operating temperature	20	35	°C
Storage temperature	-40	85	°C
Laser current above I_{th}		100	mA
Laser reverse voltage		1.0	V
Laser reverse current		10	μA
Monitor diode bias		-10	V
Heatpump voltage		2.4	V
Fiber bend radius	30		mm

Reliability/Quality

Meets Qualification requirements of Telcordia / Bellcore GR468-Core for central office environment.
 Operating reliability <math>< 500 \text{ FITs}^1</math> in 15 years. Reliability figures for other life conditions available upon request.
 1- Assumes laser die submount held at <math>< 35^\circ\text{C}</math> by internal thermoelectric cooler, mean forward current of 35 mA, and end of life limits based on 10 mA increase in Ith and 25 % change in laser efficiency.

Safety Information

Laser safety classifications:-
 IEC60825-1: Edition 1.2 Class 1M
 21CFR1040.10 Class IIIB

Electrostatic discharge:-
 ESD threshold >500V

TA-TSY-000870 class 3.

Outline Drawing and Pinout Information

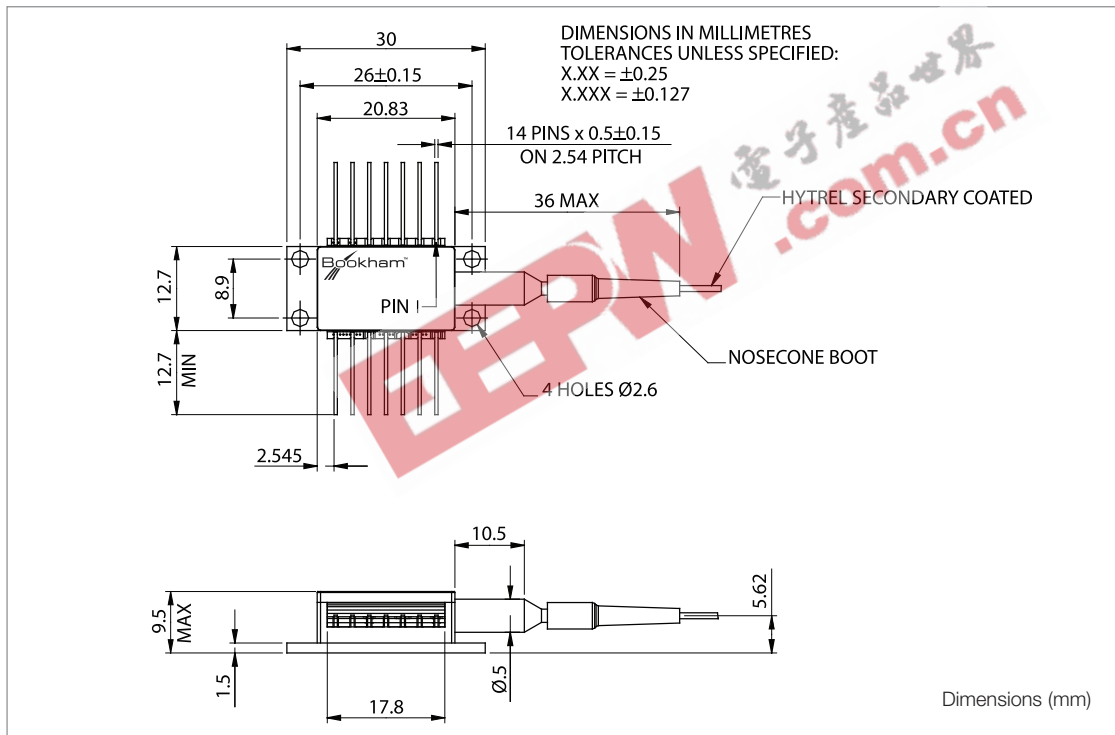

Figure 1: Outline Drawing and Pinout Information.

Instructions for Use – LC25WC

Pin 1 and Pin 2 Thermistor

The thermistor is used in a control loop in conjunction with the thermo-electric cooler to maintain the laser submount temperature at the required value for wavelength. Operating current should be less than 100 μ A to prevent self-heating errors.

Pin 3 Laser DC bias (-)

Laser bias current (negative with respect to package ground) is applied via this pin which forms one side of the bias-T connection to the laser cathode.

Pin 4 Monitor anode, Pin 5 Monitor cathode

The back facet monitor provides a mean power reference for the laser and is normally operated with a 5 V reverse bias.

Pin 6 TEC (+), Pin 7 TEC (-)

Applying a positive voltage on pin 6 with respect to pin 7 will cause the internal submount to be cooled relative to the case temperature. Reversing the polarity will raise the submount temperature relative to the case. The TEC supply should be capable of delivering up to 0.9 A at 2.4 V.

Pin 8, 9, 11, 13 Case ground

These pins must be grounded in all applications.

Pin 10

This pin is not connected. It should be grounded if possible.

Pin 12 Laser modulation (-)

The data input (modulation current) is applied via this pin which is a nominal 25 Ohm impedance coplanar line. For 10mW applications the end of life modulation current is 90mA. For all other applications 60mA maximum modulation current should be provisioned.

Pin 14 N/C

This pin is not connected. It should be grounded if possible.

Connections

Pin #	Function	Pin #	Function
1	Thermistor	8	Case Ground
2	Thermistor	9	Case Ground
3	Laser DC bias (-)	10	Not Connected
4	Monitor Anode (-)	11	Case Ground
5	Monitor Cathode (+)	12	Laser Modulation (-)
6	TEC (+)	13	Case Ground
7	TEC (-)	14	Not Connected

RoHS Compliance



Bookham is fully committed to environment protection and sustainable development and has set in place a comprehensive program for removing polluting and hazardous substances from all of its products. The relevant evidence of RoHS compliance is held as part of our controlled documentation for each of our compliant products. RoHS compliance parts are available to order, please refer to the ordering information section for further details.

Ordering Information:

LC25WC	[Wavelength]	[Power Option]	[Reach]	[Connector]
	***	E = 2 mWpk C = 3 mWpk A = 4 mWpk B = 10 mWpk	G = 80 km	J28 = SC/PC J34 = FC/PC J57 = LC J59 = MU

*** = First three digits of wavelength value E.g. for $\lambda_p = 1530 \text{ nm}$ *** = 153
Fibre length 1130 to 1190 mm.

Other connector types are available on request.

E.g. LC25WC153AG-J28 is a 4 mW 1530nm device with an SC connector for use in an 80 km application.

Contact Information

North America Bookham Worldwide Headquarters

2584 Junction Ave.
San Jose
CA 95134
USA

- Tel: +1 408 919 1500
- Fax: +1 408 919 6083

www.bookham.com
sales@bookham.com

Europe Paignton Office

Brixham Road
Paignton
Devon
TQ4 7BE
United Kingdom

- Tel: +44 (0) 1803 66 2000
- Fax: +44 (0) 1803 66 2801

Asia Shenzhen Office

2 Phoenix Road
Futian Free Trade Zone
Shenzhen 518038
China

- Tel: +86 755 33305888
- Fax: +86 755 33305805
+86 755 33305807

Important Notice

Performance figures, data and any illustrative material provided in this data sheet are typical and must be specifically confirmed in writing by Bookham before they become applicable to any particular order or contract. In accordance with the Bookham policy of continuous improvement specifications may change without notice. The publication of information in this data sheet does not imply freedom from patent or other protective rights of Bookham or others. Further details are available from any Bookham sales representative.



INVISIBLE LASER RADIATION
DO NOT VIEW DIRECTLY WITH
OPTICAL INSTRUMENTS
CLASS 1M LASER
REFERENCE IEC 60825-1: Edition 1.2



Caution - use of controls or adjustments or performance of procedures other than those specified herein may result in hazardous radiation exposure.