

DATA SHEET

For a complete data sheet, please also download:

- The IC06 74HC/HCT/HCU/HCMOS Logic Family Specifications
- The IC06 74HC/HCT/HCU/HCMOS Logic Package Information
- The IC06 74HC/HCT/HCU/HCMOS Logic Package Outlines

EEPW 电子产品世界
.com.cn

74HC/HCT7597

8-bit shift register with input latches

Product specification
File under Integrated Circuits, IC06

December 1990

8-bit shift register with input latches

74HC/HCT7597

FEATURES

- 8-bit parallel input latches
- Shift register has direct overriding load and clear
- Output capability: standard
- I_{CC} category: MSI

GENERAL DESCRIPTION

The 74HC/HCT7597 are high-speed Si-gate CMOS devices and are pin compatible with low power Schottky TTL (LSTTL). They are specified in compliance with JEDEC standard no. 7A.

The 74HC/HCT7597 both consist of an 8-bit storage latch feeding a parallel-in, serial-out 8-bit shift register.

When \overline{LE} is LOW, data at the D_n inputs enter the latches. In this condition the latches are transparent, i.e. a latch output will change state each time its corresponding D-input changes.

When \overline{LE} is HIGH the latches store the information that was present at the D-inputs, a set-up time preceding the LOW-to-HIGH transition of \overline{LE} .

The shift register has a positive edge-triggered clock, direct load (from storage) and clear inputs.

QUICK REFERENCE DATA

GND = 0 V; $T_{amb} = 25\text{ }^{\circ}\text{C}$; $t_r = t_f = 6\text{ ns}$

SYMBOL	PARAMETER	CONDITIONS	TYPICAL		UNIT
			HC	HCT	
t_{PHL}/t_{PLH}	propagation delay	$C_L = 15\text{ pF}$; $V_{CC} = 5\text{ V}$			
	SH_{CP} to Q		15	17	ns
	\overline{LE} to Q		22	27	ns
	\overline{PL} to Q		20	23	ns
	D_7 to Q		20	24	ns
f_{max}	maximum clock frequency SH_{CP}		99	79	MHz
C_I	input capacitance		3.5	3.5	pF
C_{PD}	power dissipation capacitance per package	notes 1, 2	29	30	pF

Notes

1. C_{PD} is used to determine the dynamic power dissipation (P_D in μW):

$$P_D = C_{PD} \times V_{CC}^2 \times f_i + \sum (C_L \times V_{CC}^2 \times f_o) \text{ where:}$$

f_i = input frequency in MHz; f_o = output frequency in MHz

$\sum (C_L \times V_{CC}^2 \times f_o)$ = sum of outputs

C_L = output load capacitance in pF; V_{CC} = supply voltage in V

2. For HC the condition is $V_I = \text{GND to } V_{CC}$; for HCT the condition is $V_I = \text{GND to } V_{CC} - 1.5\text{ V}$

ORDERING INFORMATION

See "74HC/HCT/HCU/HCMOS Logic Package Information".

8-bit shift register with input latches

74HC/HCT7597

PIN DESCRIPTION

PIN NO.	SYMBOL	NAME AND FUNCTION
8	GND	ground (0 V)
9	Q	serial data output
10	$\overline{\text{MR}}$	asynchronous reset input (active LOW)
11	SH_{CP}	shift clock input (LOW-to-HIGH, edge-triggered)
12	$\overline{\text{LE}}$	latch enable input (active LOW)
13	$\overline{\text{PL}}$	parallel load input (active LOW)
14	D_S	serial data input
15, 1, 2, 3, 4, 5, 6, 7	D_0 to D_7	parallel data inputs
16	V_{CC}	positive supply voltage

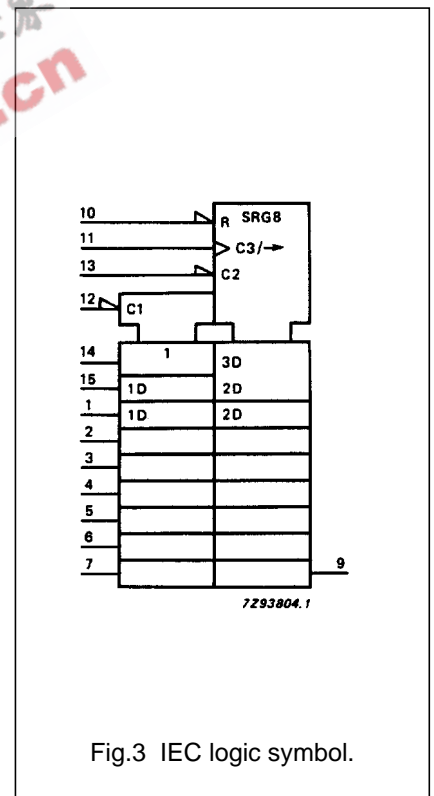
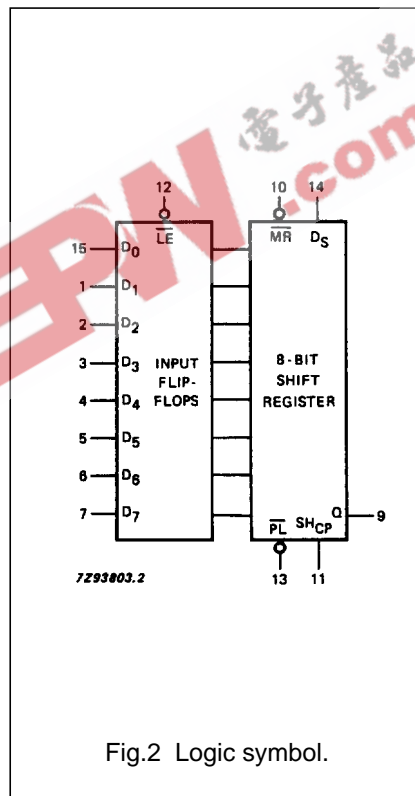
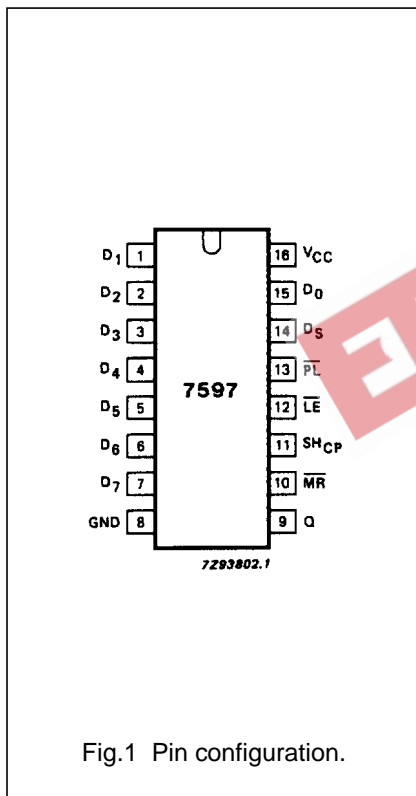

8-bit shift register with input latches

74HC/HCT7597

FUNCTION TABLE

\overline{LE}	SH_{CP}	\overline{PL}	\overline{MR}	FUNCTION
L	X	X	X	data enabled to input latches (transparent)
H	X	X	X	data stored into latches (non-transparent)
X	X	L	H	data transferred from input latches to shift register
X	X	L	L	invalid logic, state of shift register indeterminate when signals removed
X	X	H	L	shift register cleared
X	↑	H	H	shift register clocked $Q_n = Q_{n-1}, Q_0 = D_S$

Notes

- H = HIGH voltage level
 L = LOW voltage level
 X = don't care
 ↑ = LOW-to-HIGH CP transition

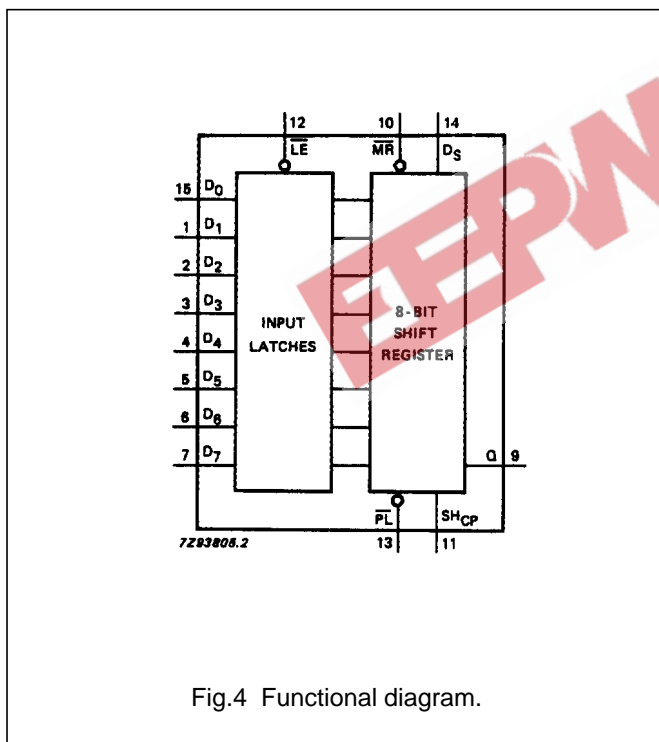

8-bit shift register with input latches

74HC/HCT7597

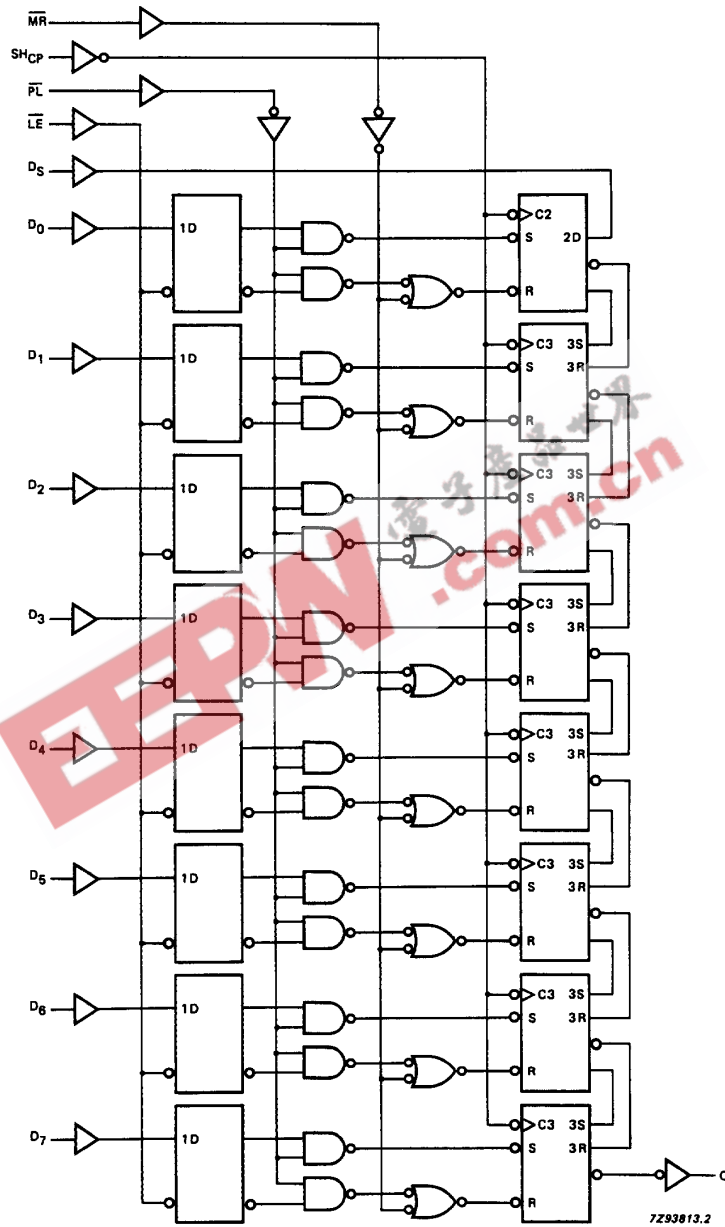

Fig.5 Logic diagram.

8-bit shift register with input latches

74HC/HCT7597

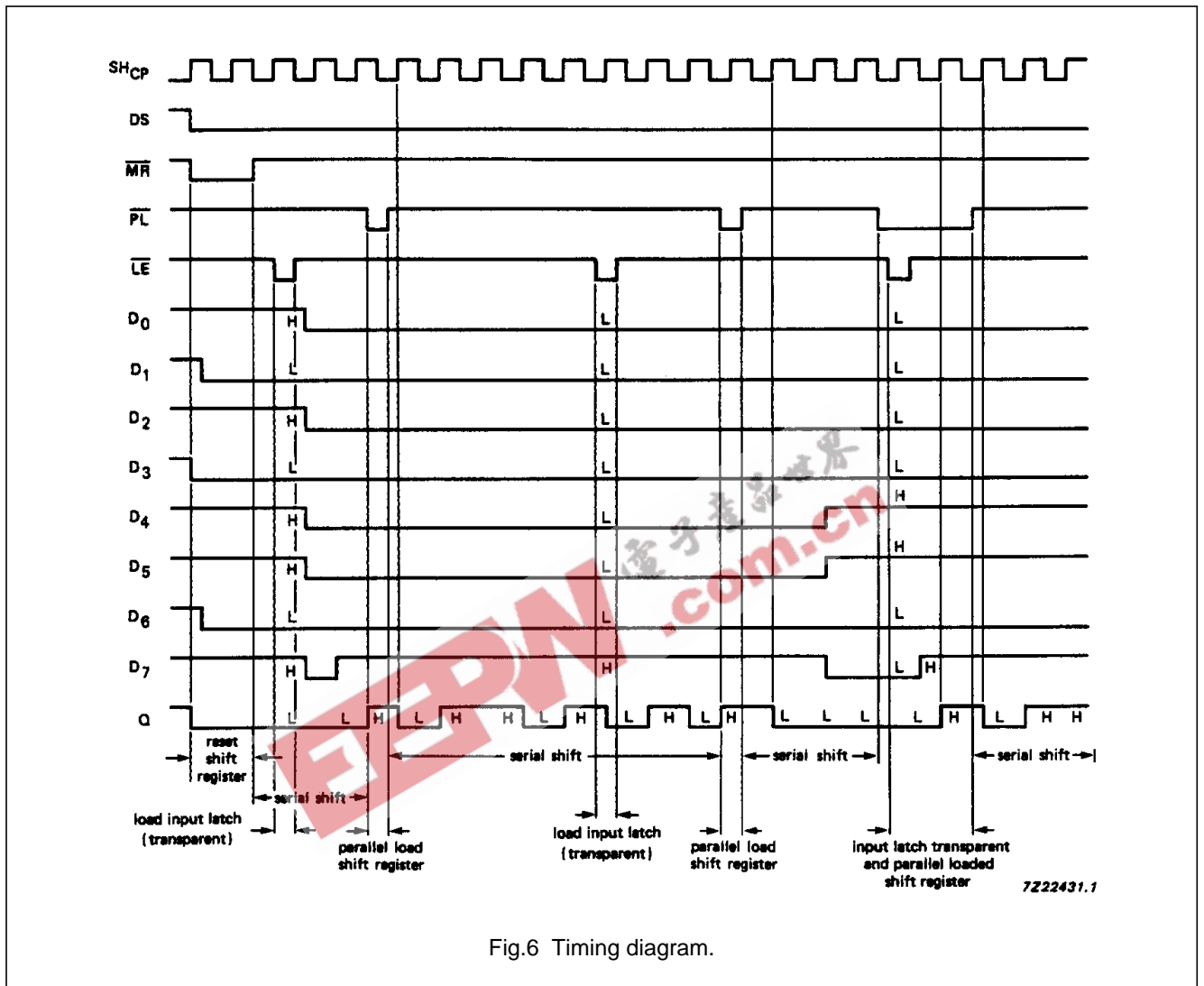

Fig.6 Timing diagram.

8-bit shift register with input latches

74HC/HCT7597

DC CHARACTERISTICS FOR 74HC

For the DC characteristics see *"74HC/HCT/HCU/HCMOS Logic Family Specifications"*.

Output capability: standard

I_{CC} category: MSI

AC CHARACTERISTICS FOR 74HC

GND = 0 V; t_r = t_f = 6 ns; C_L = 50 pF

SYMBOL	PARAMETER	T _{amb} (°C)						UNIT	TEST CONDITIONS		
		74HC							V _{CC} (V)	WAVEFORMS	
		+25			-40 to +85		-40 to +125				
		min.	typ.	max.	min.	max.	min.				max.
t _{PHL} / t _{PLH}	propagation delay SH _{CP} to Q		50 18 14	175 35 30		220 44 37	265 53 45	ns	2.0 4.5 6.0	Fig.7	
t _{PHL}	propagation delay MR to Q		52 19 15	175 35 30		220 44 37	265 53 45	ns	2.0 4.5 6.0	Fig.7	
t _{PHL} / t _{PLH}	propagation delay LE to Q		72 26 21	250 50 43		315 63 54	375 75 64	ns	2.0 4.5 6.0	Fig.7	
t _{PHL} / t _{PLH}	propagation delay PL to Q		63 23 18	190 38 32		240 48 41	285 57 48	ns	2.0 4.5 6.0	Fig.7	
t _{PHL} / t _{PLH}	propagation delay D ₇ to Q		63 23 18	190 38 32		240 48 41	285 57 48	ns	2.0 4.5 6.0	Fig.7	
t _{THL} / t _{TLH}	output transition time		19 7 6	75 15 13		95 19 16	110 22 19	ns	2.0 4.5 6.0	Fig.7	
t _w	SH _{CP} pulse width HIGH or LOW	80 16 14	11 4 3		100 20 17		120 24 20	ns	2.0 4.5 6.0	Fig.7	
t _w	LE pulse width LOW	80 16 14	11 4 3		100 20 17		120 24 20	ns	2.0 4.5 6.0	Fig.7	
t _w	MR pulse width LOW	80 16 14	17 6 5		100 20 17		120 24 20	ns	2.0 4.5 6.0	Fig.7	
t _w	PL pulse width LOW	80 16 14	17 6 5		100 20 17		120 24 20	ns	2.0 4.5 6.0	Fig.7	
t _{rem}	removal time MR to SH _{CP}	50 10 9	-3 -1 -1		65 13 11		75 15 13	ns	2.0 4.5 6.0	Fig.7	

8-bit shift register with input latches

74HC/HCT7597

SYMBOL	PARAMETER	T _{amb} (°C)							UNIT	TEST CONDITIONS	
		74HC								V _{CC} (V)	WAVEFORMS
		+25			-40 to +85		-40 to +125				
		min.	typ.	max.	min.	max.	min.	max.			
t _{rem}	removal time \overline{MR} to \overline{PL}	100 20 17	22 8 6		125 25 21		150 30 26	ns	2.0 4.5 6.0	Fig.7	
t _{su}	set-up time D _n to \overline{LE}	80 16 14	6 2 2		100 20 17		120 24 20	ns	2.0 4.5 6.0	Fig.7	
t _{su}	set-up time D _S to SH _{CP}	80 16 14	11 4 3		100 20 17		120 24 20	ns	2.0 4.5 6.0	Fig.7	
t _{su}	set-up time \overline{PL} to SH _{CP}	80 16 14	8 3 2		100 20 17		120 24 20	ns	2.0 4.5 6.0	Fig.7	
t _h	hold time D _n to \overline{LE}	4 4 4	-3 -1 -1		4 4 4		4 4 4	ns	2.0 4.5 6.0	Fig.7	
t _h	hold time D _S to SH _{CP}	2 2 2	-8 -3 -2		2 2 2		2 2 2	ns	2.0 4.5 6.0	Fig.7	
t _h	hold time \overline{PL} to SH _{CP}	2 2 2	-8 -3 -2		2 2 2		2 2 2	ns	2.0 4.5 6.0	Fig.7	
f _{max}	maximum pulse frequency SH _{CP}	6.0 30 35	30 90 107		4.8 24 28		4.0 20 24	MHz	2.0 4.5 6.0	Fig.7	

8-bit shift register with input latches

74HC/HCT7597

DC CHARACTERISTICS FOR 74HCT

For the DC characteristics see *"74HC/HCT/HCU/HCMOS Logic Family Specifications"*.

Output capability: standard

I_{CC} category: MSI

Note to HCT types

The value of additional quiescent supply current (ΔI_{CC}) for a unit load of 1 is given in the family specifications.

To determine ΔI_{CC} per input, multiply this value by the unit load coefficient shown in the table below.

INPUT	UNIT LOAD COEFFICIENT
D _S	0.25
D _n	0.40
PL, MR	1.50
LE, SH _{CP}	1.50

AC CHARACTERISTICS FOR 74HCT

GND = 0 V; t_r = t_f = 6 ns; C_L = 50 pF

SYMBOL	PARAMETER	T _{amb} (°C)								UNIT	TEST CONDITIONS	
		74HCT									V _{CC} (V)	WAVEFORMS
		+25			-40 to +85		-40 to +125					
		min.	typ.	max.	min.	max.	min.	max.				
t _{PHL} / t _{PLH}	propagation delay SH _{CP} to Q		20	35		44		53	ns	4.5	Fig.7	
t _{PHL}	propagation delay MR to Q		25	42		53		63	ns	4.5	Fig.7	
t _{PHL} / t _{PLH}	propagation delay LE to Q		31	53		66		80	ns	4.5	Fig.7	
t _{PHL} / t _{PLH}	propagation delay PL to Q		27	46		58		69	ns	4.5	Fig.7	
t _{PHL} / t _{PLH}	propagation delay D ₇ to Q		28	49		61		74	ns	4.5	Fig.7	
t _{THL} / t _{TLH}	output transition time		7	15		19		22	ns	4.5	Fig.7	
t _w	SH _{CP} pulse width HIGH or LOW	16	6		20		24		ns	4.5	Fig.7	
t _w	LE pulse width LOW	16	7		20		24		ns	4.5	Fig.7	
t _w	MR pulse width LOW	20	11		25		30		ns	4.5	Fig.7	
t _w	PL pulse width LOW	18	9		23		27		ns	4.5	Fig.7	
t _{rem}	removal time MR to SH _{CP}	10	-1		13		15		ns	4.5	Fig.7	
t _{rem}	removal time MR to PL	20	9		25		30		ns	4.5	Fig.7	

8-bit shift register with input latches

74HC/HCT7597

SYMBOL	PARAMETER	T _{amb} (°C)						UNIT	TEST CONDITIONS		
		74HCT							V _{CC} (V)	WAVEFORMS	
		+25			-40 to +85		-40 to +125				
		min.	typ.	max.	min.	max.	min.				max.
t _{su}	set-up time D _n to \overline{LE}	16	5		20		24		ns	4.5	Fig.7
t _{su}	set-up time D _S to SH _{CP}	16	5		20		24		ns	4.5	Fig.7
t _{su}	set-up time \overline{PL} to SH _{CP}	16	3		20		24		ns	4.5	Fig.7
t _h	hold time D _n to \overline{LE}	4	-2		4		4		ns	4.5	Fig.7
t _h	hold time D _S to SH _{CP}	2	-4		2		2		ns	4.5	Fig.7
t _h	hold time \overline{PL} to SH _{CP}	2	-3		2		2		ns	4.5	Fig.7
f _{max}	maximum pulse frequency SH _{CP}	30	72		24		20		MHz	4.5	Fig.7

8-bit shift register with input latches

74HC/HCT7597

AC WAVEFORMS

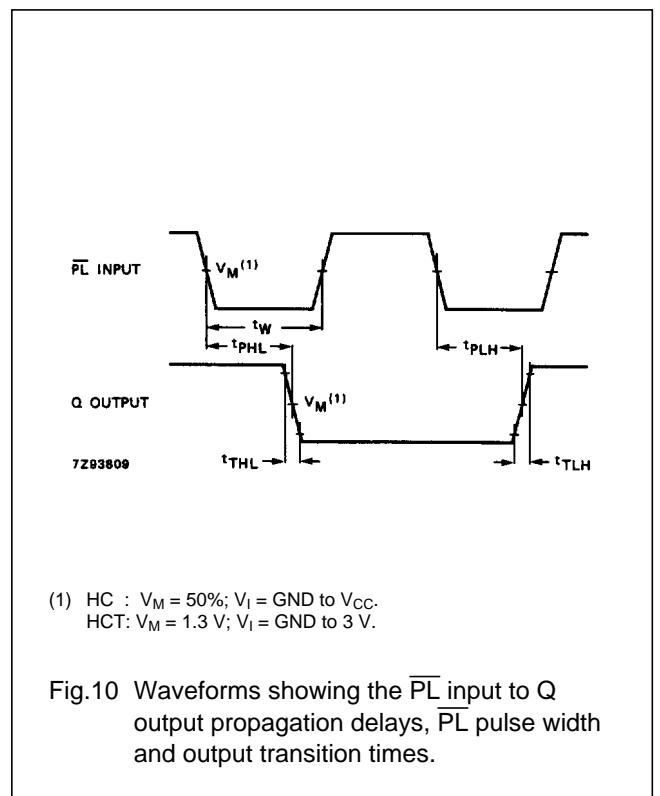
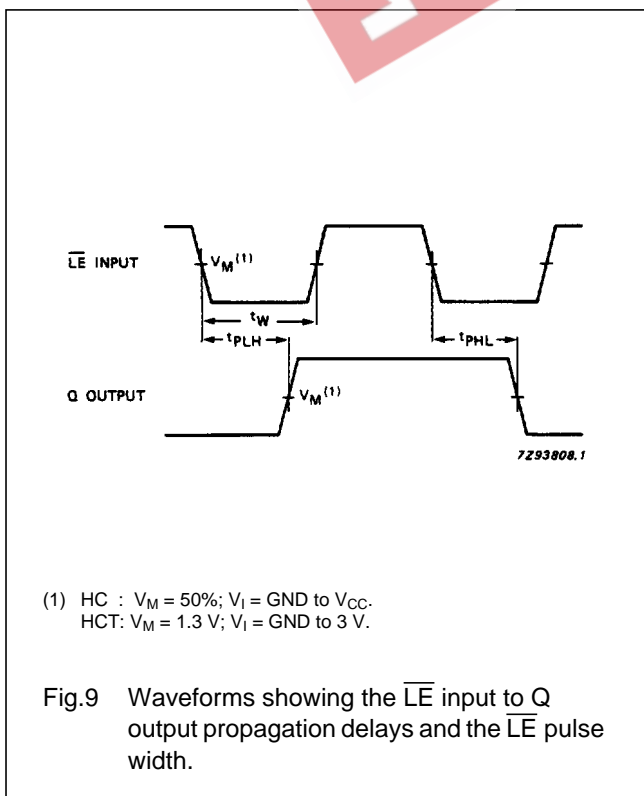
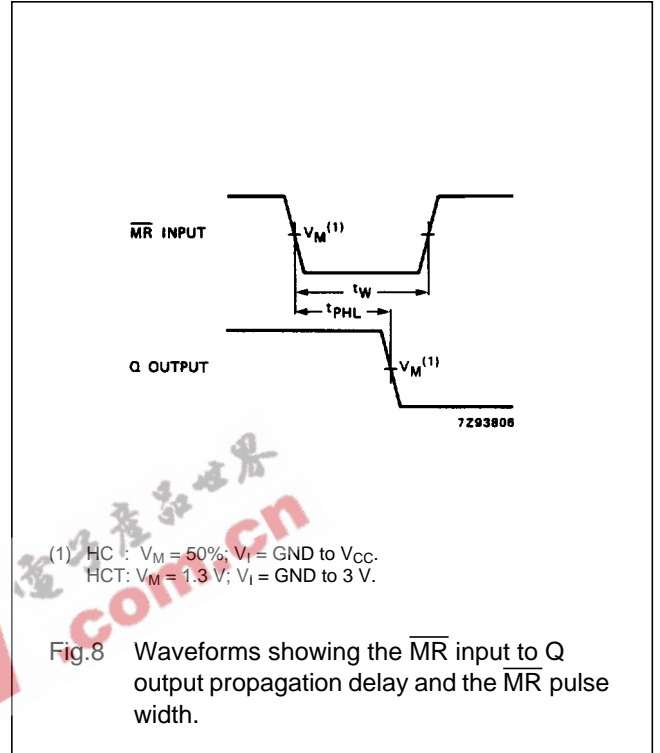
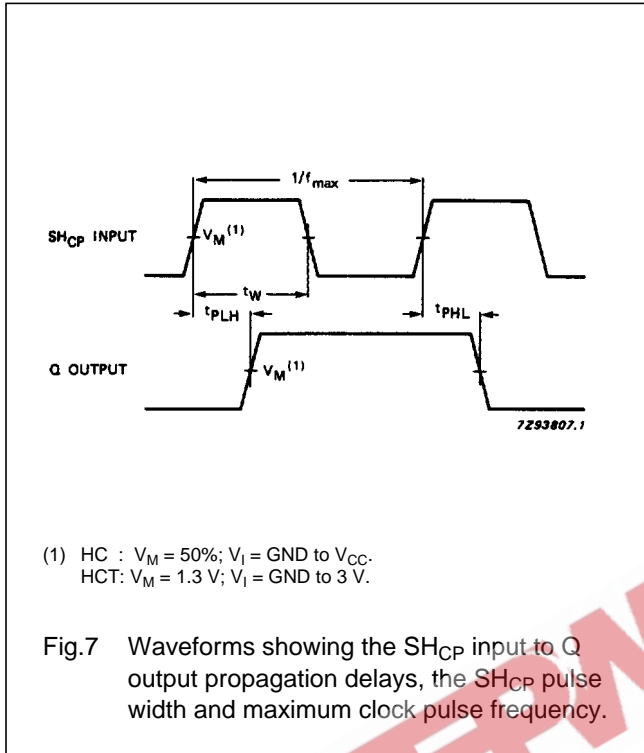

8-bit shift register with input latches

74HC/HCT7597

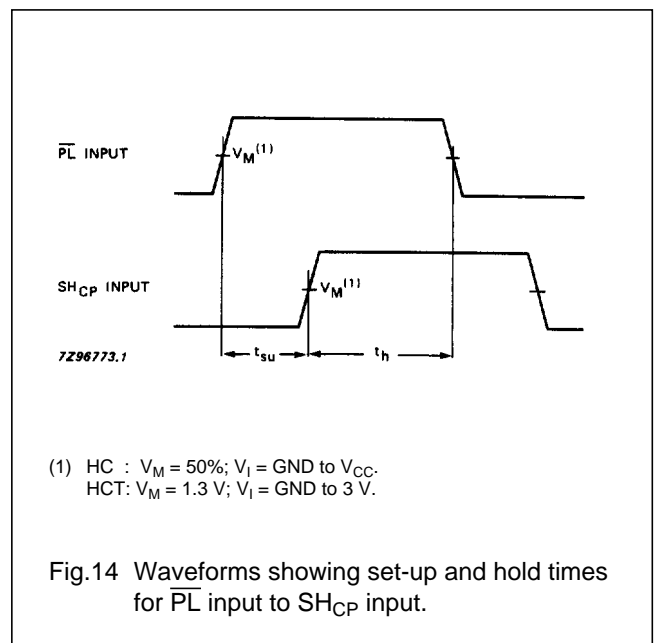
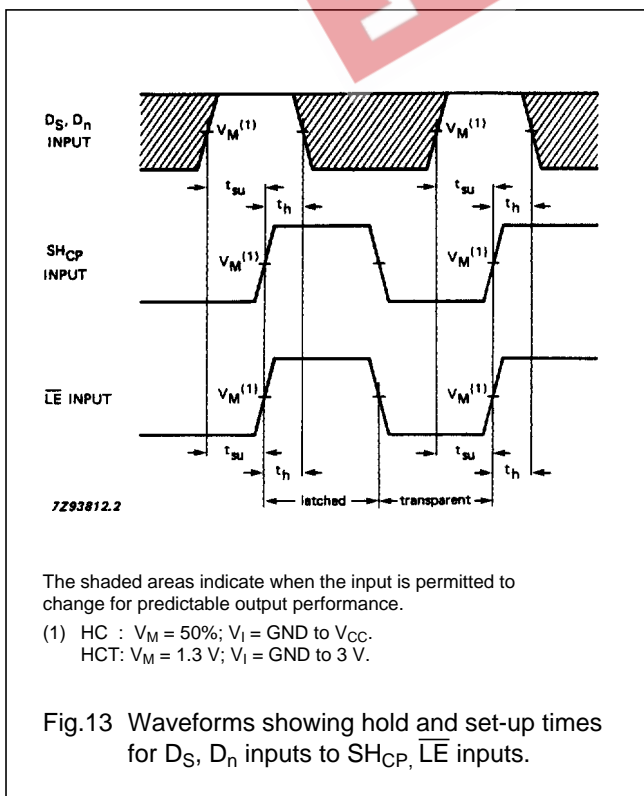
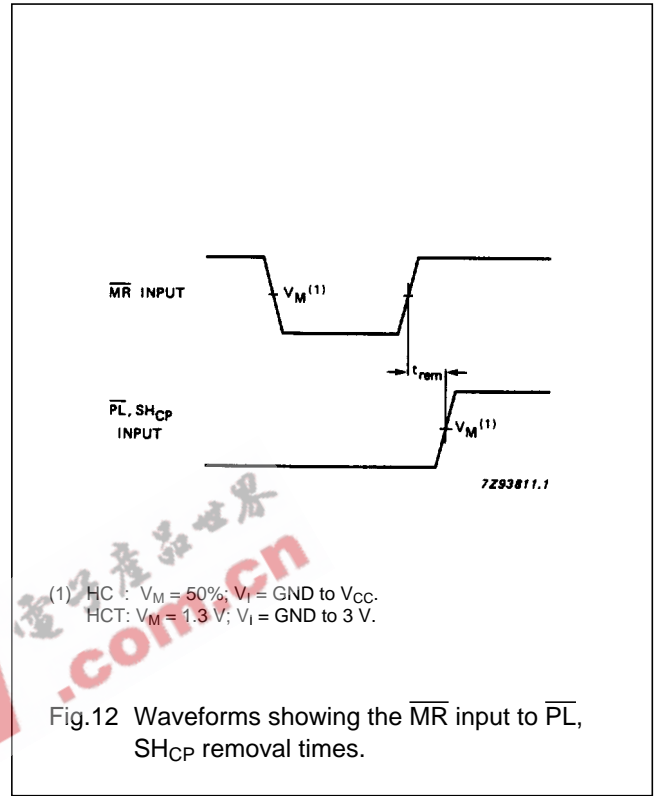
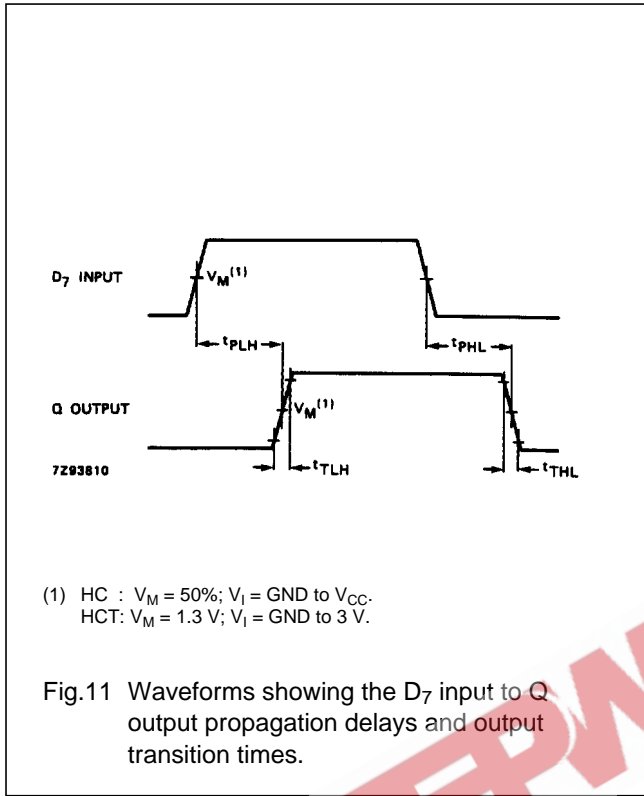

PACKAGE OUTLINES

See "74HC/HCT/HCU/HCMOS Logic Package Outlines".