

# AZ DISPLAYS, INC.

---

## SPECIFICATIONS FOR LIQUID CRYSTAL DISPLAY

PART NUMBER:

ACM0801C

DATE:

September 6, 2005

## 1. General Specification

Interface With Parallel MPU

Display Specification

Display Mode: Positive/Transflective/STN Type

Viewing Angle : 6:00 Clock

Display Duty: 1/8    Driving Bias: 1/4    Driving Voltage 3.3V

Mechanical Characteristics (Unit: mm)

Display Dot Matrix : 8\*1

External Dimension: See Drawing

Dots Size: 0.54\*0.64

Dots Pitch: 0.605\*0.70

Temperature Specification

Operation Temperature: -20 ~ 70°C

Storage Temperature: -25 ~ 75°C



## External Dimension

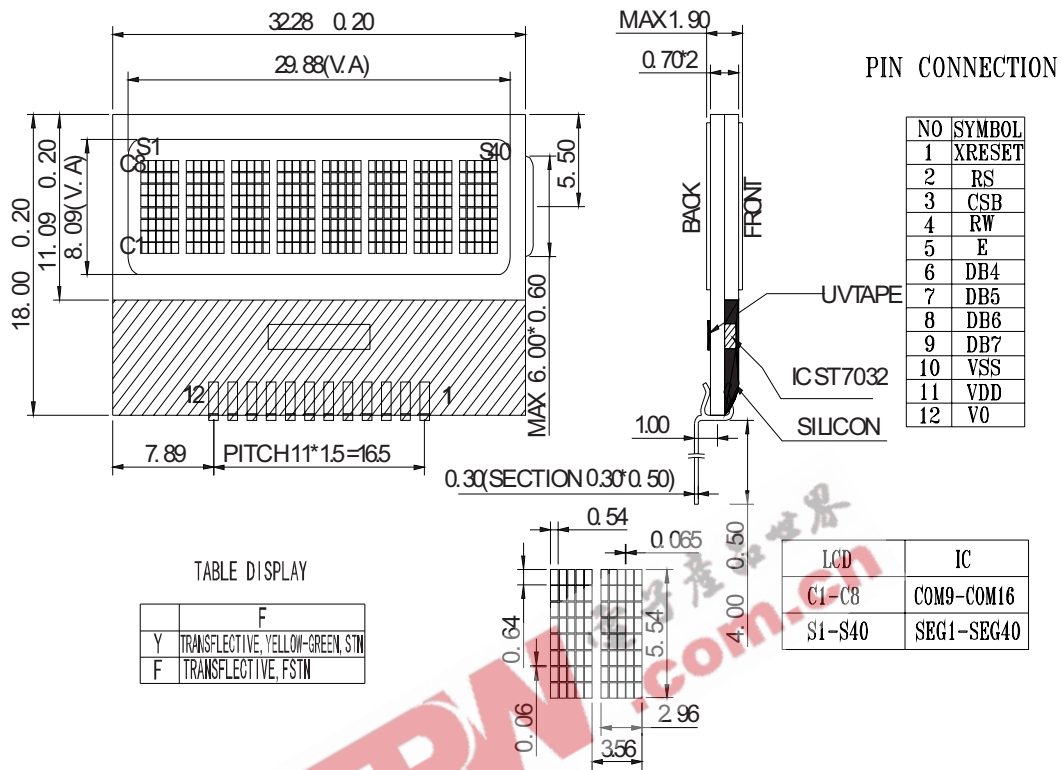

### PIN CONNECTION

NO	SYMBOL
1	XRESET
2	RS
3	CSB
4	RW
5	E
6	DB4
7	DB5
8	DB6
9	DB7
10	VSS
11	VDD
12	V0

### TABLE DISPLAY

	F
Y	TRANSFLECTIVE, YELLOW-GREEN, STM
F	TRANSFLECTIVE, FSTN

LCD	IC
C1-C8	COM9-COM16
S1-S40	SEG1-SEG40

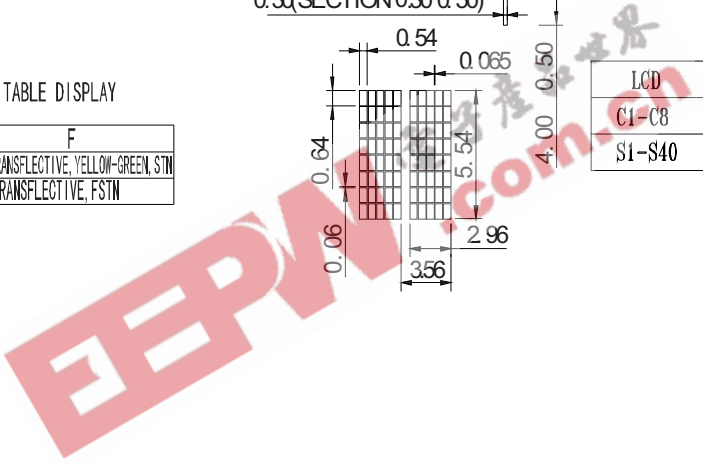

## PIN Assignment

Pin	Symbol	Function
1	XRESET	External reset pin. Low active.
2	RS	Select register. 0: Instruction register (for write) Busy flag & address counter (for read) 1: Data register (for write and read).
3	CSB	Chip select in parallel mode and serial interface (Low active)
4	R/W	Read/write select signal.
5	E	Operation (data read/write) enable signal.
6	DB4	Four high order bi-directional three-state data bus pin. Used for data transfer and receive between the MPU and the ST7032. DB7 can be used as a busy flag. In serial interface mode DB7 is S (input data), DB6 is SCL (serial clock).
7	DB5	
8	DB6	
9	DB7	
10	VSS	Signal ground for LCM (GND)
11	VDD	Power supply for logic for LCM
12	V0	Contrast adjust

## Absolute Maximum Ratings

Power supply voltage	VDD-VSS	0	-	7.0	V
Input voltage	VIN	VSS	-	VDD	
Operating temperature range	T <sub>A</sub>	-20	-	+70	°C
Storage temperature range	T <sub>STO</sub>	-25	-	+75	

\*Wide temperature range is available

## DC Characteristics

Parameter	Symbol	Conditions	Mn.	Typ.	Max.	Unit
Supply voltage for LCD	VDD-V0	T <sub>a</sub> = 25°C	-	3.3	-	V
Operating voltage	VDD		2.7	5.0	5.5	
Supply current	I <sub>DD</sub>	T <sub>a</sub> = 25°C VDD = 5.0V	-	0.8	1.0	mA
Input leakage current	I <sub>LKG</sub>		-	-	2.0	uA

HI level input voltage	VIH		2.2	-	VDD	V
LI level input voltage	VIL	Twice initial value or less	0	-	0.6	
HI level output voltage	VOH	LOH=- 0.25mA	2.4	-	-	
LI level output voltage	VOL	LOH=1.6mA	-	-	0.4	
Backlight supply voltage	VF		-	5.0	-	

EEPW 电子产品世界 .com.cn

## AC Characteristics

● 68 Interface

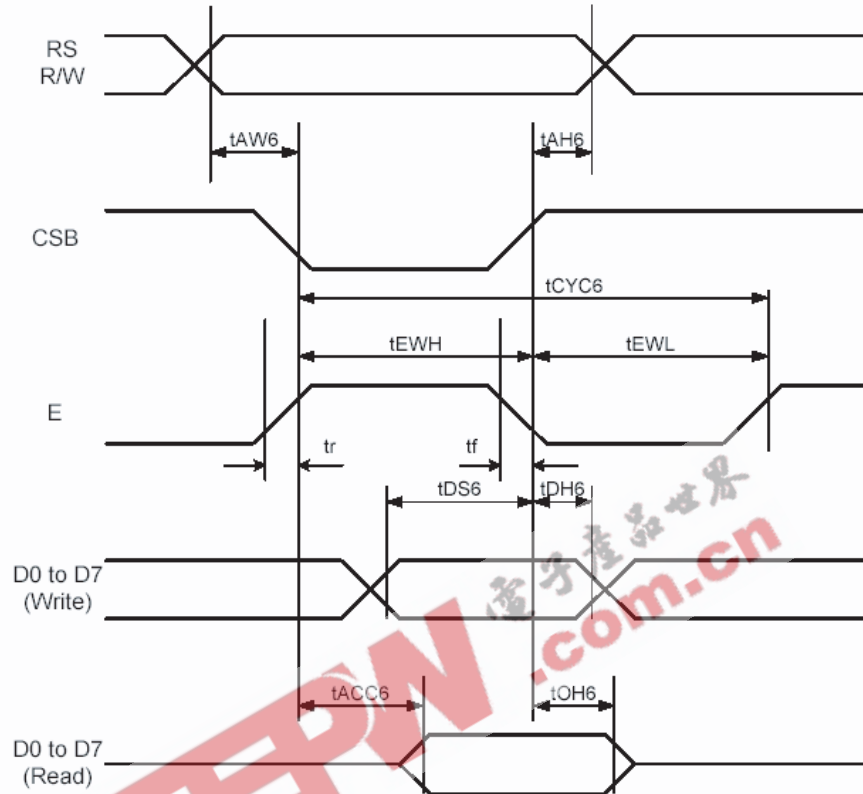

( $T_a = -40$  to  $85^\circ\text{C}$ )

Item	Signal	Symbol	Condition	VDD=2.7 to 4.5V Rating		VDD=4.5 to 5.5V Rating		Units
				Min.	Max.	Min.	Max.	
Address hold time	RS	$t_{AH6}$	—	20	-	20	-	ns
Address setup time	RS	$t_{AW6}$		20	-	20	-	
System cycle time	RS	$t_{CYC6}$	—	250	-	150	-	ns
Data setup time	D0 to D7	$t_{DS6}$	—	100	-	80	-	ns
Data hold time	D0 to D7	$t_{DH6}$		40	-	20	-	
Access time	D0 to D7	$t_{ACC6}$	$C_L = 100 \text{ pF}$	-	500	-	400	ns
Output disable time	D0 to D7	$t_{OH6}$		300	-	150	-	
Enable Rise/Fall time	E	$t_r, t_f$	—	-	20	-	20	ns
Enable H pulse time	E	$t_{EWH}$	—	200	-	120	-	ns
Enable L pulse time	E	$t_{EWL}$	—	50	-	30	-	ns

Note: All timing is specified using 20% and 80% of  $V_{DD}$  as the reference.

● Serial Interface

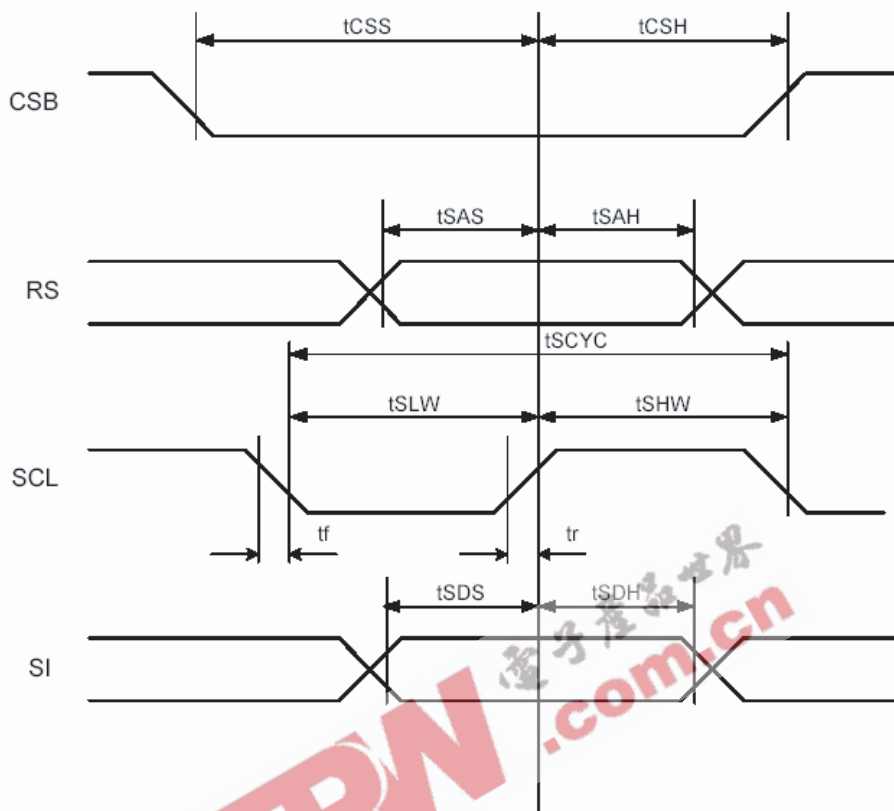

(Ta = -40 to 85°C)

Item	Signal	Symbol	Condition	VDD=2.7 to 4.5V Rating		VDD=4.5 to 5.5V Rating		Units
				Min.	Max.	Min.	Max.	
Serial Clock Period	SCL	tscyc	—	200	-	100	-	ns
SCL "H" pulse width		tshw		20	-	20	-	
SCL "L" pulse width		tslw		160	-	120	-	
SCL Rise/Fall time	SCL	tr,tf	—	-	20	-	20	ns
Address setup time	RS	tsas	—	10	-	10	-	ns
Address hold time		tсах		250	-	150	-	
Data setup time	SI	tsds	—	10	-	10	-	ns
Data hold time		tсdh		10	-	20	-	
CS-SCL time	CS	tcss	—	20	-	20	-	ns
		tсsh		350	-	200	-	

\*1 All timina is specified usina 20% and 80% of V<sub>DD</sub> as the standard.

● Internal Power Supply Reset

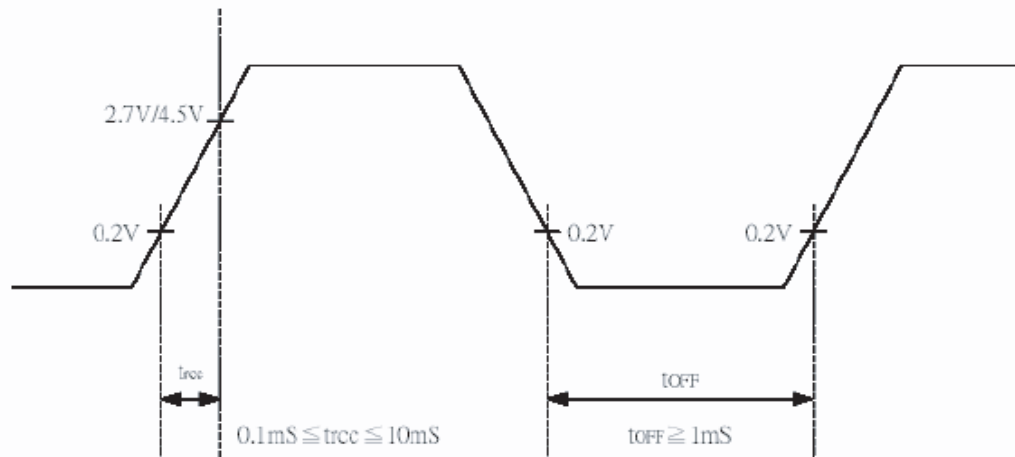

Notes:

- $t_{OFF}$  compensates for the power oscillation period caused by momentary power supply oscillations.
- Specified at 4.5V for 5V operation, and at 2.7V for 3V operation.
- For if 4.5V is not reached during 5V operation, the internal reset circuit will not operate normally.

● Hardware reset(XRESET)

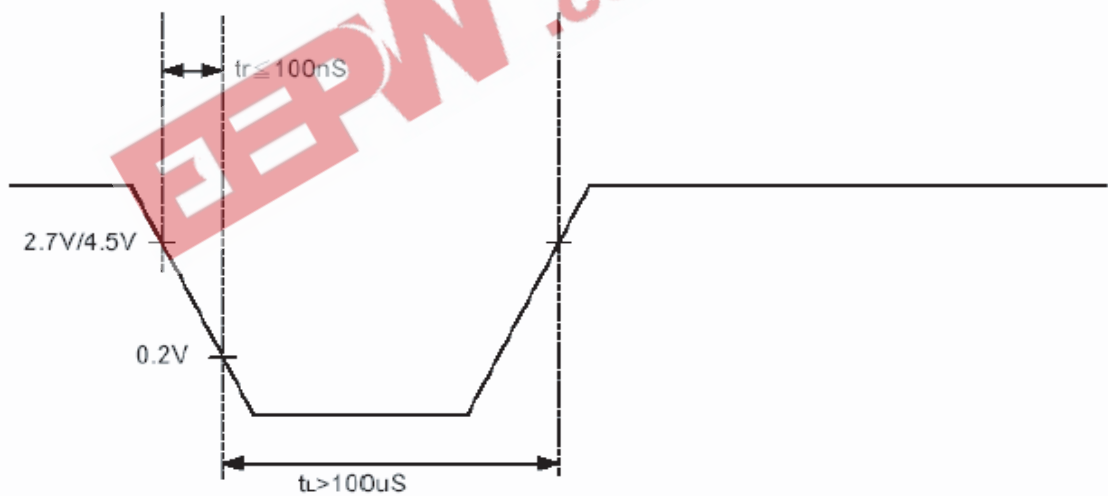

## IC Specification

See The Reference Of Sitronix Data Book----ST7032



## Instruction Table

➤ instruction table at “Normal mode”  
 (when “EXT” option pin connect to VDD, the instruction set follow below table)

Instruction	Instruction Code										Description	Instruction Execution Time		
	RS	R/W	DB7	DB6	DB5	DB4	DB3	DB2	DB1	DB0		OSC=380KHz	OSC=540kHz	OSC=700KHz
Clear Display	0	0	0	0	0	0	0	0	0	1	Write "20H" to DDRAM, and set DDRAM address to "00H" from AC	1.08 ms	0.76 ms	0.59 ms
Return Home	0	0	0	0	0	0	0	0	1	x	Set DDRAM address to "00H" from AC and return cursor to its original position if shifted. The contents of DDRAM are not changed.	1.08 ms	0.76 ms	0.59 ms
Entry Mode Set	0	0	0	0	0	0	0	1	I/D	S	Sets cursor move direction and specifies display shift. These operations are performed during data write and read.	26.3 us	18.5 us	14.3 us
Display ON/OFF	0	0	0	0	0	0	1	D	C	B	D=1:entire display on C=1:cursor on B=1:cursor position on	26.3 us	18.5 us	14.3 us
Cursor or Display Shift	0	0	0	0	0	1	S/C	R/L	x	x	S/C and R/L: Set cursor moving and display shift control bit, and the direction, without changing DDRAM data.	26.3 us	18.5 us	14.3 us
Function Set	0	0	0	0	1	DL	N	x	x	x	DL: interface data is 8/4 bits N: number of line is 2/1	26.3 us	18.5 us	14.3 us
Set CGRAM	0	0	0	1	AC5	AC4	AC3	AC2	AC1	AC0	Set CGRAM address in address counter	26.3 us	18.5 us	14.3 us
Set DDRAM address	0	0	1	AC6	AC5	AC4	AC3	AC2	AC1	AC0	Set DDRAM address in address counter	26.3 us	18.5 us	14.3 us
Read Busy flag and address	0	1	BF	AC6	AC5	AC4	AC3	AC2	AC1	AC0	Whether during internal operation or not can be known by reading BF. The contents of address counter can also be read.	0	0	0
Write data to RAM	1	0	D7	D6	D5	D4	D3	D2	D1	D0	Write data into internal RAM (DDRAM/CGRAM)	26.3 us	18.5 us	14.3 us
Read data from RAM	1	1	D7	D6	D5	D4	D3	D2	D1	D0	Read data from internal RAM (DDRAM/CGRAM)	26.3 us	18.5 us	14.3 us

Note:

Be sure the ST7032 is not in the busy state (BF = 0) before sending an instruction from the MPU to the ST7032. If an instruction is sent without checking the busy flag, the time between the first instruction and next instruction will take much longer than the instruction time itself. Refer to Instruction Table for the list of each instruction execution time.

➤ **instruction table at "Extension mode"**  
 (when "EXT" option pin connect to VSS, the instruction set follow below table)

Instruction	Instruction Code										Description	Instruction Execution Time		
	RS	R/W	DB7	DB6	DB5	DB4	DB3	DB2	DB1	DB0		OSC=380KHz	OSC=540kHz	OSC=700KHz
Clear Display	0	0	0	0	0	0	0	0	0	1	Write "20H" to DDRAM. and set DDRAM address to "00H" from AC	1.08 ms	0.76 ms	0.59 ms
Return Home	0	0	0	0	0	0	0	0	1	x	Set DDRAM address to "00H" from AC and return cursor to its original position if shifted. The contents of DDRAM are not changed.	1.08 ms	0.76 ms	0.59 ms
Entry Mode Set	0	0	0	0	0	0	0	1	I/D	S	Sets cursor move direction and specifies display shift. These operations are performed during data write and read.	26.3 us	18.5 us	14.3 us
Display ON/OFF	0	0	0	0	0	0	1	D	C	B	D=1:entire display on C=1:cursor on B=1:cursor position on	26.3 us	18.5 us	14.3 us
Function Set	0	0	0	0	1	DL	N	DH	*0	IS	DL: interface data is 8/4 bits N: number of line is 2/1 DH: double height font IS: instruction table select	26.3 us	18.5 us	14.3 us
Set DDRAM address	0	0	1	AC6	AC5	AC4	AC3	AC2	AC1	AC0	Set DDRAM address in address counter	26.3 us	18.5 us	14.3 us
Read Busy flag and address	0	1	BF	AC6	AC5	AC4	AC3	AC2	AC1	AC0	Whether during internal operation or not can be known by reading BF. The contents of address counter can also be read.	0	0	0
Write data to RAM	1	0	D7	D6	D5	D4	D3	D2	D1	D0	Write data into internal RAM (DDRAM/CGRAM/ICONRAM)	26.3 us	18.5 us	14.3 us
Read data from RAM	1	1	D7	D6	D5	D4	D3	D2	D1	D0	Read data from internal RAM (DDRAM/CGRAM/ICONRAM)	26.3 us	18.5 us	14.3 us

Note \*: this bit is for test command, and must always set to "0"

Instruction table 0(IS=0)														
Cursor or Display Shift	0	0	0	0	0	1	S/C	R/L	x	x	S/C and R/L: Set cursor moving and display shift control bit, and the direction, without changing DDRAM data.	26.3 us	18.5 us	14.3 us
Set CGRAM	0	0	0	1	AC5	AC4	AC3	AC2	AC1	AC0	Set CGRAM address in address counter	26.3 us	18.5 us	14.3 us

Instruction table 1(IS=1)														
Internal OSC frequency	0	0	0	0	0	1	BS	F2	F1	F0	BS=1:1/4 bias BS=0:1/5 bias F2~0: adjust internal OSC frequency for FR frequency.	26.3 us	18.5 us	14.3 us
Set ICON address	0	0	0	1	0	0	AC3	AC2	AC1	AC0	Set ICON address in address counter.	26.3 us	18.5 us	14.3 us
Power/ICON control/Contrast set	0	0	0	1	0	1	Ion	Bon	C5	C4	Ion: ICON display on/off Bon: set booster circuit on/off C5,C4: Contrast set for internal follower mode.	26.3 us	18.5 us	14.3 us
Follower control	0	0	0	1	1	0	Fon	Rab2	Rab1	Rab0	Fon: set follower circuit on/off Rab2~0: select follower amplified ratio.	26.3 us	18.5 us	14.3 us
Contrast set	0	0	0	1	1	1	C3	C2	C1	C0	Contrast set for internal follower mode.	26.3 us	18.5 us	14.3 us

## Block Diagram

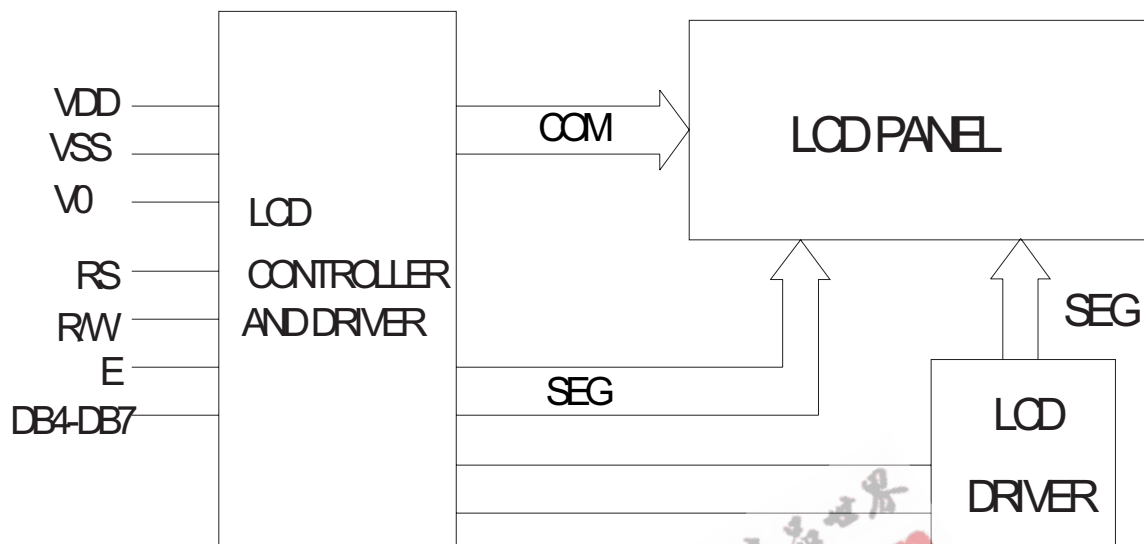

EEPW.com.cn 电子产品世界